



TECHNICAL SPECIFICATIONS

---

# I N D I V I D U A L   C H E E S E   D R A I N E R S



#### RAW MATERIALS

All our products are made of first-conversion Polyethylene or Polypropylene of certified food grade quality. Colouring possible

#### SAFE X™ RANGE

All our injection-moulded parts can be made of our X-ray-detectable material for security against foreign objects

#### INDIVIDUAL CHEESE DRAINERS

For your orders of individual moulds and cheese strainers, contact our distributors, of which you will find the adress list below

[www.groupemedicos.com/distributeurs-mino-gaillard.html](http://www.groupemedicos.com/distributeurs-mino-gaillard.html)





#### BLOCKFORMS AND TRAYS

Designed according to the customer's need, they are designed for the production process, based on existing cell models or new injection matrixes. The components (cells and prehensile handles) are assembled by polyfusion

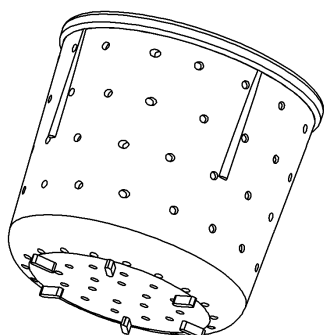
## INDIVIDUAL CHEESE DRAINERS





### SELECTIONAL CHEESESTRAINERS WITH «ROUNDED EDGE» BOTTOM»

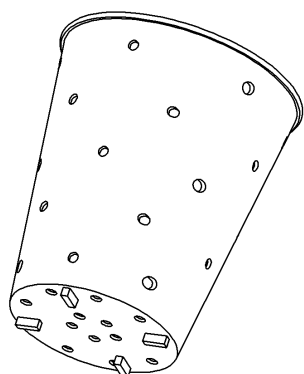

				
PF 3633 000	82	63	120	216
PF 3635 000	69	64	120	105
PF 3341 000	77	66	63	450
PF 3783 000	70	68	40	455
PF 3772 000	74	69	40	360
PF 3342 000	96	76	96	380
PF 3345 000	87	82	73	240
PF 3346 000	89	82	83	120
PF 3743 000	98	88	86	180
PF 3809 000	100	90	105	112
PF 3402 000	99	92	78	112
PF 3847 000	110	110	90	42
PF 4069 000	135	135	65	66
PF 3524 000	190	180	93	24
PF 3889 000	200	200	150	8
PF 3859 000	210	210	90	16

### SELECTIONAL CHEESE STRAINERS WITH «SHARP EDGED» BOTTOM







				
PF 3397 000	60	50	54	924
PF 4357 000	65	50	260	135
PF 3455 000	65	51	80	640
PF 3344 000	79	56	96	540
PF 3931 000	62	58	58	336
PF 3394 000	69	58	118	210
PF 3398 000	69	59	58	280
PF 3785 000	72	59	55	510
PF 3603 000	73	63	140	120
PF 3607 000	80	65	80	420
PF 3412 000	80	68	125	180
PF 3933 001	80	70	70	312
PF 3734 000	90	70	105	280
PF 3620 000	110	90	150	90
PF 3403 000	119	97	96	156
PF 3686 000	108	98	86	120
PF 3404 000	135	108	123	198

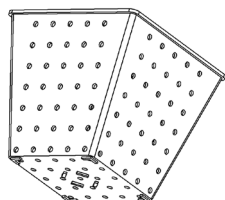



## INDIVIDUAL CHEESE DRAINERS

### PYRAMIDAL CHEESE STRAINERS WITH «SHARP EDGE» BOTTOM







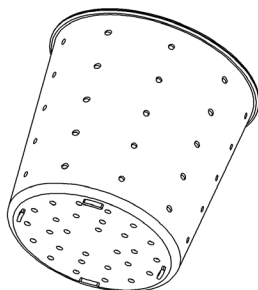

				
PF 3822 000	87 x 87	30 x 30	120	440
PF 3594 000	100 x 100	50 x 50	130	180
PF 3343 000	85 x 85	57 x 57	80	640

### EXTENSION FOR PF 3344 000 - PF 3412 000 - PF 3607 000

				
PF 3706 000	87	80	50	378





### «RANGE 6000» CHEESE STRAINERS

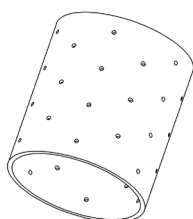

				
PF 6002 001	73	48	153	210
PF 6003 001	78	65	63	308
PF 6004 001	77	63	96	308
PF 6005 001	80	68	70	360
PF 6006 001	82	70	135	100
PF 6007 000	87	74	85	168
PF 6008 000	94	80	96	180
PF 6010 001	100	82	110	180
PF 6011 001	108	108	58	60
PF 6012 001	120	100	100	156
PF 6013 001	120	100	110	144
PF 6014 001	Heart (110x110x110)		45	400
PF 6015 001	200	200	100	24
PF 6017 001	Ø 200 BOTTOMLESS		100	16

### BOTTOMLESS INDIVIDUAL MOULDS WITH HOLES





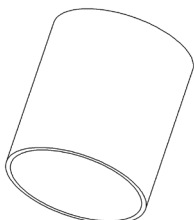

				
PF 3952 000	48	48	200	168
PF 3582 000	55	55	200	132
PF 3639 000	63	63	138	135
PF4039 000	65	65	100	120
PF 3531 000	85	85	100	60
PF 3878 000	90	90	130	72
PF 3658 000	100	100	100	48
PF 3864 000	110	110	110	60
PF 3513 000	115	115	100	36
PF 3520 000	115	115	130	45
PF 3863 000	130	130	111	48
PF 4003 002	130	130	300	18
PF 3876 000	180	180	100	24
PF 3851 000	180	180	110	24
PF 3865 002	200	200	170	12
PF 3771 001	200	200	190	10
PF 3842 000	Square of 100 x 100		110	60

## INDIVIDUAL CHEESE DRAINERS





### BOTTOMLESS INDIVIDUAL MOULDS WITHOUT HOLE

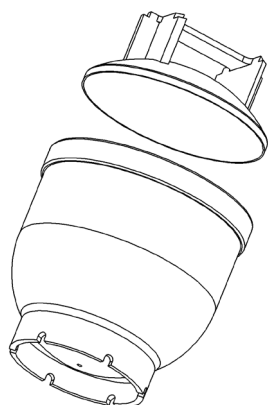

				
PF 4003 001	130	130	300	18
PF 3943 000	188	188	150	10
PF 3865 001	200	200	170	12
PF 3989 001	200	200	180	12
PF 3771 002	200	200	190	10





### MISCELLANEOUS MOULDS

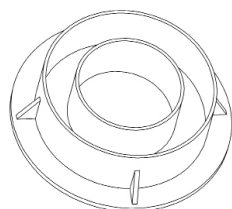

			COMMENTS	
PF 3611 001	89	60	Baby 200g without piston	60
PF 3617 000	100	68	Baby 250g with piston	90
PF 3839 000	105	120	Mini Gouda 650g	48
PF 3840 000	104	45	Piston for PF 3839 000	160
PF 4015 000	160	165	Bol Edam 2 Kg	18
PF 4016 000	153	75	Piston for PF 4015 000	36
PF 4017 000	195	185	Bol Mimolette 4 Kg	12
PF 4018 000	191	80	Piston for PF 4017 000	24
PF 4263 000	350	180	Bleu de Gex Salting basin	A l'unité
PF 4030 000	350	210	Bleu de Gex Salting basin	A l'unité
PF 4226 001	ØH110 ØB85	65	White cheese strainer for «Brouuse»	416
PF 4226 002	ØH110 ØB85	65	Green cheese strainer for «Brouuse»	416
PF 3700 000	ØH115 ØB90	82	cheese strainer for «Brouuse»	240
PF 3709 000	ØH145 ØB110	93	cheese strainer for «Brouuse»	160
PF 3710 000	ØH155 ØB122	86	cheese strainer for «Brouuse»	120

### PRESSING PISTONS



			COMMENTS	
PF 3962 000	113	50	For PF 3513 000 / PF 3520 000	90
PF 4141 000	132	5	For PF 4069 000	165
PF 3726 000	132	45	For PF 4069 000	84
PF 3758 000	175	50	For PF 3851 000 / PF 3876 000	36
PF 3757 000	180	50	For PF 3851 000 / PF 3876 000	36
PF 4035 000	188	50	For PF 3524 000 / PF 3943 000	48
PF 3888 000	200	50	For PF 3771 001/002 PF 3889 000 PF 3865 001/002 PF 3989 000	54

## Icon keys

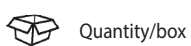
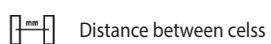
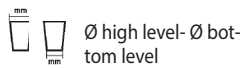
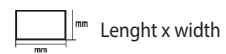
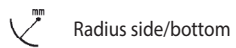
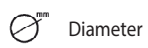



## TECHNICAL SPECIFICATIONS

---

# B O T T O M L E S S B L O C K F O R M S

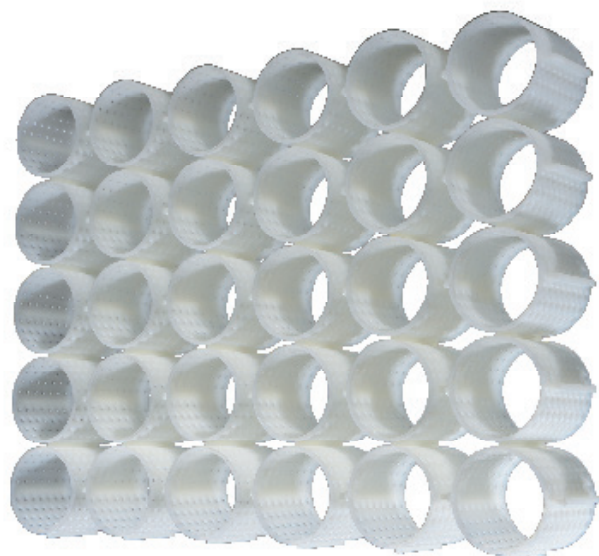

#### RAW MATERIALS

All our products are made of first-conversion Polyethylene or Polypropylene of certified food grade quality. Colouring possible

#### SAFE X™ RANGE

All our injection-moulded parts can be made of our X-ray-detectable material for security against foreign objects

#### INDIVIDUAL CHEESE DRAINERS

For your orders of individual moulds and cheese strainers, contact our distributors, of which you will find the adress list below  
[www.groupemedicos.com/distributeurs-mino-gaillard.html](http://www.groupemedicos.com/distributeurs-mino-gaillard.html)

#### BLOCKFORMS AND TRAYS

Designed according to the customer's need, they are designed for the production process, based on existing cell models or new injection matrixes. The components (cells and prehensile handles) are assembled by polyfusion



## BOTTOMLESS BLOCKFORMS

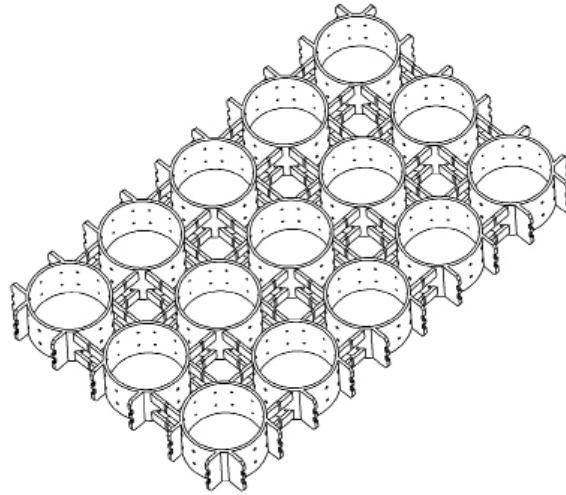





### ROUNDED SHAPES

			Extension	
45	50	53,5 x 51	NON	
48	70	60 x 58	NON	
	99	52 x 52	NON	
57	125	70,2 x 66,7	NON	
60	64	81,5 x 79	NON	
	90	88 x 77	OUI	50
65	70	96 x 96	OUI	40
68	80	78 x 85,4	OUI	80
70	130	78 x 78	NON	
73	83	95 x 95	NON	
77	90	88 x 98,5	OUI	50
80	45	124,8 x 124,5	OUI	45
	65	102,8 x 94	OUI	50
	90	114 x 88	OUI	60
83	54	90 x 90	NON	
85	80	98,9 x 102,4	NON	
95	80	105 x 135	OUI	80
96	70	116 x 116	OUI	70
100	35	119 x 119	NON	
	75	110 x 123	OUI	50
105	54	110 x 110	NON	
	100	110 x 110	NON	
107	65	116 x 116	OUI	50
110	70	117,2 x 116,5	OUI	30
115	80	126 x 128	OUI	80
127	100	132 x 132	NON	
140	58	147 x 155	OUI	40
145	52	158 x 164	OUI	37
	75	176 x 154	OUI	65
	81	192 x 155	NON	
	100	192 x 161	NON	
150	68	169 x 177,3	NON	
	85	176,5 x 164	OUI	40
170	80	214 x 226	OUI	60
	85	220 x 245	OUI	50
190	45	214 X 214	OUI	14
	75	220 x 245	OUI	50
	130	214 x 226	OUI	90



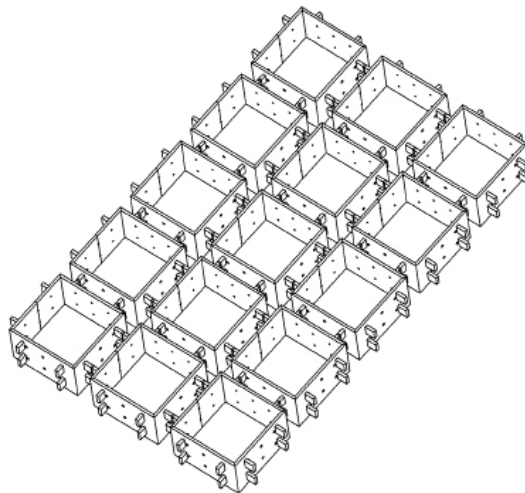

## BOTTOMLESS BLOCKFORMS

### ROUNDES SHAPES (CONTINUED)

			Extension	
200	75	214 x 226	OUI	65
	80	210 x 270	OUI	80
205	55	240 x 230	OUI	60
210	85	220 x 245	OUI	50
220	55	256 x 252	OUI	50
235	90	294 X 245	OUI	50
240	65	282 x 282	NON	
285	50	293 x 470	OUI	30
340	67	350 x 471	OUI	50
	75	510 x 491	OUI	50





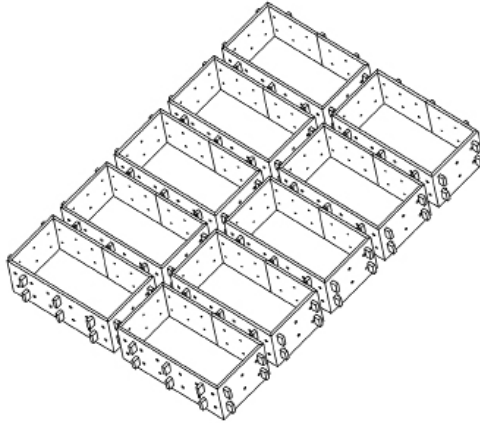

### SQUARE SHAPES

			Extension	
62 x 62	130	78 x 78	NON	
90 x 90	40	97 x 99	OUI	40
	75	116 x 116	OUI	65
	85	110 x 123	OUI	50
95 x 95	75	125 x 125	OUI	50
		116 x 116	OUI	65
100 x 100	110	112 x 112	NON	
110 x 110	57	121 x 121	NON	
127 x 127	90	150 x 150	NON	
180 x 180	49	239 x 219	NON	
	70	299 x 239	NON	
	120	232 x 232	OUI	50

## BOTTOMLESS BLOCKFORMS





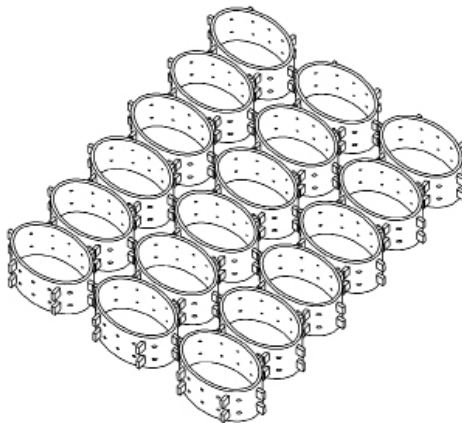

### RECTANGULAR SHAPES

			Extension	
120 x 60	59	138 x 80	NON	
	63	138 x 80	NON	
	70	138 x 80	NON	
135 x 63	120	144 x 71	NON	
150 x 70	80	186 x 90	NON	
	90	186 x 90	NON	
180 x 99	79	196 x 116,5	OUI	60
180 x 100	75	236 x 134	OUI	45
220 x 110	140	251 x 141	OUI	15
		251 x 141	OUI	80
		251 x 141	OUI	95
		270 x 160	OUI	80
		270 x 160	OUI	100
235 x 115	75	294 x 164	OUI	50
235 x 120	110	265 x 157	OUI	55
260 x 110	75	276 x 125	OUI	35



### OVAL SHAPES

			Extension	
114 x 67	75	123 x 88	OUI	50
132 x 62	75	116 x 116	OUI	50
137 x 82	70	168 x 95	OUI	30
	75	125 x 125	OUI	35

## Icon keys



Diameter



Radius side/bottom



Length x width



Height



Ø high level- Ø bottom level



Weight



Capacity



Distance between celss



Raw material



Name



Reference



Ring



Quantity/box



TECHNICAL SPECIFICATIONS

---

# B L O C K B O T T O M S



#### RAW MATERIALS

All our products are made of first-conversion Polyethylene or Polypropylene of certified food grade quality. Colouring possible

#### SAFE X™ RANGE

All our injection-moulded parts can be made of our X-ray-detectable material for security against foreign objects

#### INDIVIDUAL CHEESE DRAINERS

For your orders of individual moulds and cheese strainers, contact our distributors, of which you will find the adress list below

[www.groupemedicos.com/distributeurs-mino-gaillard.html](http://www.groupemedicos.com/distributeurs-mino-gaillard.html)



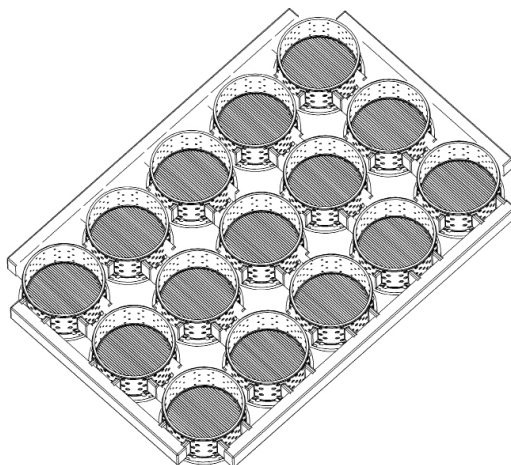

#### BLOCKFORMS AND TRAYS

Designed according to the customer's need, they are designed for the production process, based on existing cell models or new injection matrixes. The components (cells and prehensile handles) are assembled by polyfusion

## BLOCKBOTTOMS







### ROUNDED SHAPES

 mm	 mm	Bottom 	 mm	Extension	 mm
40	45	2	63,3 x 67,9	NON	
45	47	0	59 x 59	NON	
55	60	0	65,5 x 67,3	NON	
60	12	4	81,5 x 79	OUI	64
	80	7	72 x 72	OUI	25
	115,5	0	87,1 x 81,3	NON	
65	10	8	90 x 85	OUI	30
	110	0	82 x 72	NON	
	112	0	80 x 76	NON	
70	15	2,5	90 x 85	OUI	25
	65	0	89 x 89	NON	
		7	89 x 89	NON	
73	12	7	95 x 95	OUI	83
77	57	0	90 x 90	OUI	60
	70	0	90 x 89	NON	
80	49	0	89 x 89	NON	
	58	0	89 x 89	NON	
	60	7	92 x 92	OUI	55
		5	98 x 106	NON	
	65	0	89 x 89	NON	
82	35	12	98 x 98	OUI	60
83,5	50	0	92,5 x 92,5	NON	
	100	0	92,5 x 92,5	NON	
85	48	0	97 x 101	NON	
	80	0	100 x 108	OUI	60
90	53	0	135 x 100	NON	
	75	0	135 x 100	NON	
96	57	0	119,7 x 119,7	OUI	60
105	15	8	119 x 119	OUI	42
	12	7	122 x 122	OUI	44
		56	6	136 x 127,5	OUI
	57	0	119,7 x 119,7	OUI	33
		0	119,7 x 119,7	OUI	60
		0	131 x 122	OUI	33
		0	131 x 122	OUI	60
		0	120 x 120	OUI	33
	75	0	120 x 120	OUI	60
		0	147 x 132,5	NON	
0		135 x 118	OUI	50	

## BLOCKBOTTOMS

### ROUNDED SHAPES (CONTINUED)





		Bottom 		Extension	
109	110	0	128 x 119	OUI	110
110	160	0	126 x 147	NON	
112	50	0	130 x 130	NON	
113	73	0	129 x 138	NON	
	83	0	129 x 138	NON	
118	80	0	150 x 135	OUI	60
120	100	5	150 x 136	OUI	200
		5	150 x 136	OUI	100
123	56	1	145 x 159,6	OUI	60
145	12	7	192 x 161	OUI	100
	68	6	170 x 170	OUI	40
165	56,5	6	222,5 x 112,5	OUI	51
188	110	5	235 x 235	NON	
190	5	2,5	214 x 214	OUI	45
		2,5	214 x 214	OUI	14
200	75	10	218 x 218	NON	
	105	5	243 x 266	NON	
	140	0	270 x 255	NON	
	145	5	230 x 227	OUI	100
	170	0	273 x 273	NON	
	210	10	230 x 228	NON	
202	149	8	228 x 225	OUI	45
210	110	0	220 x 220	NON	
212	147	0	221 x 221	NON	
215	80	20	227 x 227	OUI	45
	90	0	245 x 245	OUI	45
	150	20	278 x 280	NON	
	190	0	245 x 245	OUI	45
230	175	20	280 x 280	NON	
235	155,5	20	273,5 x 266	NON	
240	70	10	282 x 282	OUI	65
		20	282 x 282	OUI	65
	80	10	282 x 282	OUI	65
		20	282 x 282	OUI	65

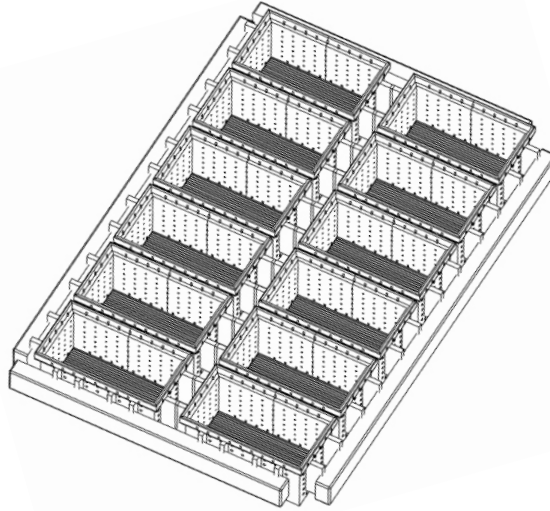

## BLOCKBOTTOMS



### RECTANGULAR SHAPES

		Bottom 		Extension	
75 x 35	70	0	106 x 63	NON	
80 x 40	82,8	0	101 x 65,5	OUI	80
100 x 50	93	0	134,5 x 78,5	OUI	80
105 x 60	80	2,5	132 x 94	NON	
105 x 85	80	5	112,5 x 135	OUI	60
110 x 40	75	0	132,5 x 68	NON	
145 x 61	42	0	161 x 86	NON	
		0	176,5 x 88	NON	
150 x 62	80	5	190 x 83	NON	
165 x 82,5	64	0	264,5 x 110	NON	
220 x 110	128	0	251 x 141	OUI	95
		0	251 x 141	OUI	80
		0	251 x 141	OUI	15
	148	0	251 x 141	NON	
		0	251 x 141	OUI	80
		0	251 x 141	OUI	100
		0	250 x 145	OUI	80
		0	270 x 160	OUI	80
		0	270 x 160	OUI	100
		0	251 x 141	OUI	50
0	251 x 141	OUI	65		
225 x 90	110	0	265 x 176,4	NON	
230 x 97	150	0	269,3 x 126,8	OUI	50
230 x 115	175	0	270 x 150	NON	
245 x 75	110	0	280 x 120	NON	
270 x 105	80	0	300 x 135	OUI	60
620 x 290	235	0	330	NON	

## BLOCKBOTTOMS



### OVAL SHAPES

		Bottom 		Extension	
108 x 66	71	0	127 x 89	NON	
113 x 68	57	0	126 x 90	OUI	33
		0	126 x 90	OUI	60
139 x 84	57	0	180 x 100	OUI	60
148 x 57	45	0	165 x 78	OUI	40
	70	0	165 x 78	OUI	25

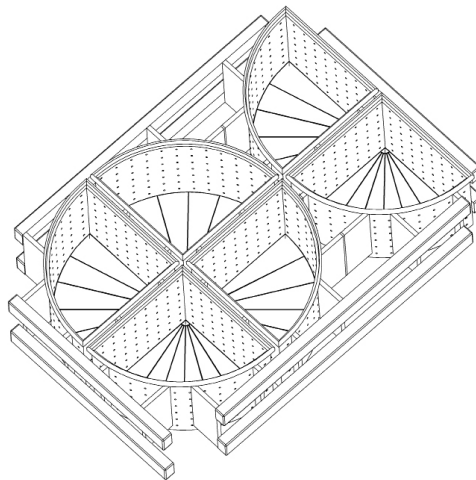



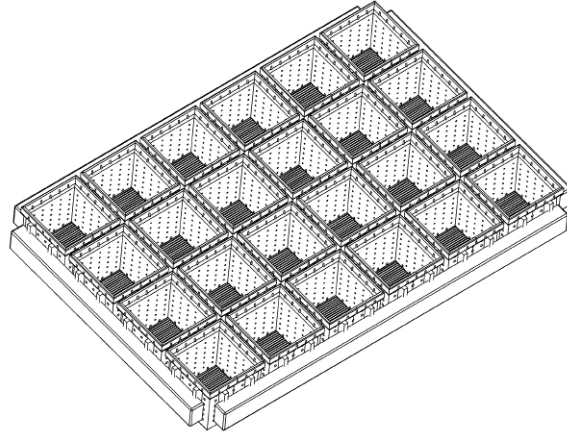

### QUARTER-CIRCLE SHAPES

		Bottom 		Extension	
Rayon 205	160	0	250 x 270	OUI	95
	160	0	250 x 270	OUI	55
	165	0	241,5 x 250	OUI	95
		0	250 x 282	NON	

## BLOCKBOTTOMS



### SQUARE SHAPES

		Bottom 		Extension	
72 x 72	69	7	95 x 95	NON	
74 x 74	69	0	99,1 x 102	NON	
75 x 75	57	0	98 x 106	OUI	33
			90 x 90	OUI	60
90 x 90	55	0	111 x 108	NON	
	57	0	119,7 x 119,7	OUI	60
95 x 95	65	0	125 x 125	OUI	20
106 x 106	63	0	125 x 125	OUI	79

## Icon keys

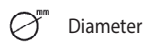

Diameter



Radius side/bottom



Length x width



Height



Ø high level-Ø bottom level



Weight



Capacity



Distance between cells



Raw material



Name



Reference



Ring



Quantity/box



TECHNICAL SPECIFICATIONS

---

# D R A I N A G E T R A Y S

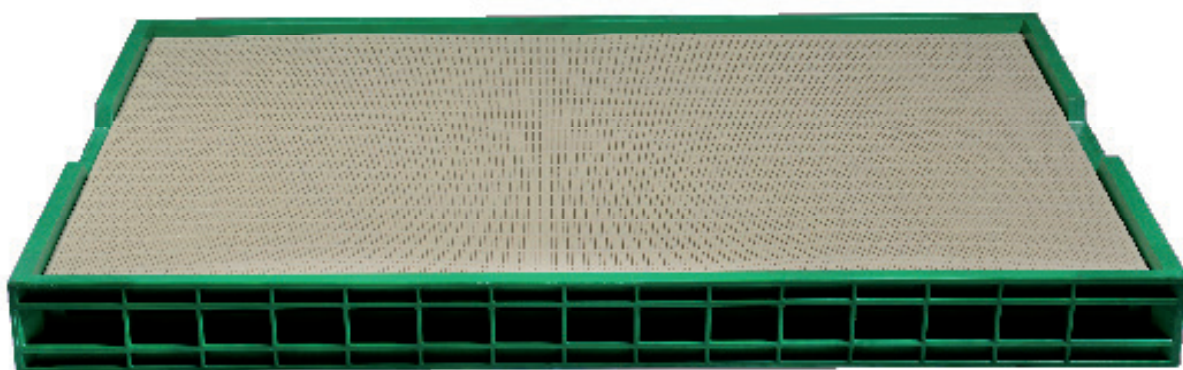

#### RAW MATERIALS

All our products are made of first-conversion Polyethylene or Polypropylene of certified food grade quality. Colouring possible

#### SAFE X™ RANGE

All our injection-moulded parts can be made of our X-ray-detectable material for security against foreign objects

#### INDIVIDUAL CHEESE DRAINERS

For your orders of individual moulds and cheese strainers, contact our distributors, of which you will find the adress list below

[www.groupemedicos.com/distributeurs-mino-gaillard.html](http://www.groupemedicos.com/distributeurs-mino-gaillard.html)

#### BLOCKFORMS AND TRAYS

Designed according to the customer's need, they are designed for the production process, based on existing cell models or new injection matrixes. The components (cells and prehensile handles) are assembled by polyfusion

## DRAINAGE TRAYS

Total dimensions	Inside dimensions	Stacking gap
760 x 505	710 x 475	40
805 x 537	775 x 507	40

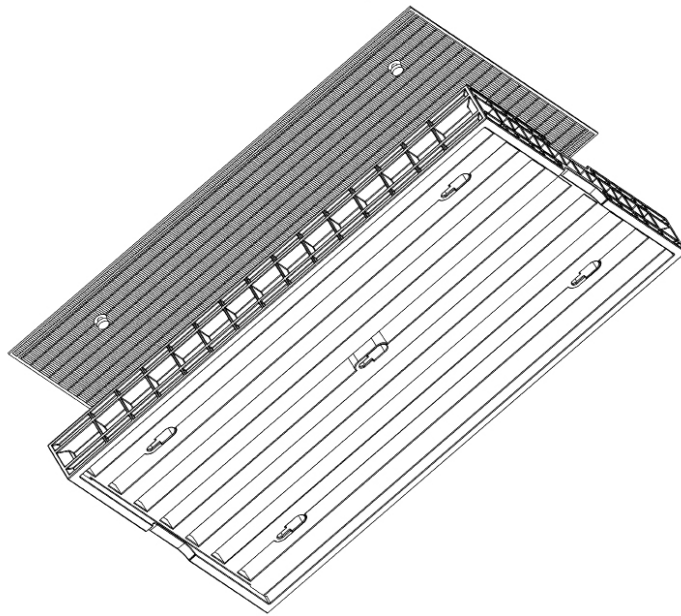

Plateaux double-face équipés de stores d'égouttage interchangeables



## TECHNICAL SPECIFICATIONS

---

# R I P E N I N G   R A C K S

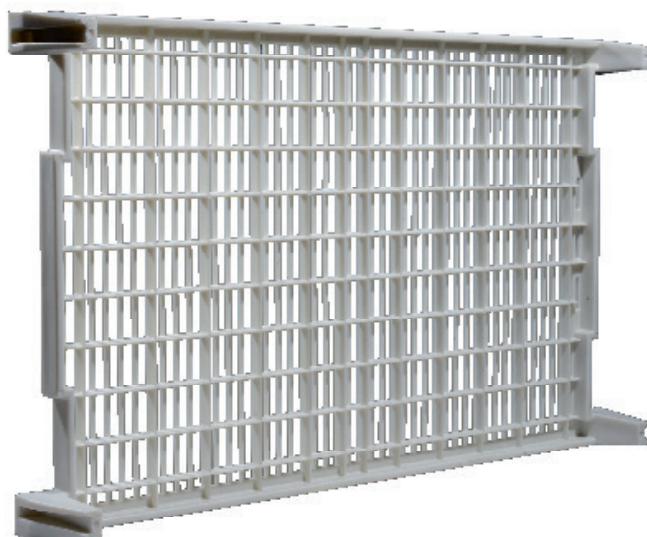



#### RAW MATERIALS

All our products are made of first-conversion Polyethylene or Polypropylene of certified food grade quality. Colouring possible

#### SAFE X™ RANGE

All our injection-moulded parts can be made of our X-ray-detectable material for security against foreign objects

#### INDIVIDUAL CHEESE DRAINERS

For your orders of individual moulds and cheese strainers, contact our distributors, of which you will find the address list below

[www.groupemedicos.com/distributeurs-mino-gaillard.html](http://www.groupemedicos.com/distributeurs-mino-gaillard.html)

#### BLOCKFORMS AND TRAYS

Designed according to the customer's need, they are designed for the production process, based on existing cell models or new injection matrixes. The components (cells and prehensile handles) are assembled by polyfusion

## RIPENING RACKS

Total dimensions	Effective surface area of cheese	Space between 2 racksH.U.
860 x 525	770 x 525	86
860 x 525	770 x 525	115

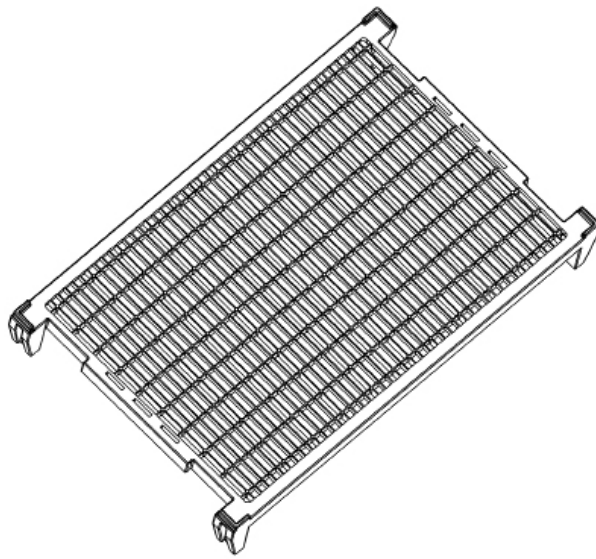

Claies d'affinage injectées en 1 seule pièce sans soudure



88, rue du Président Edouard Herriot  
69002 LYON - FRANCE  
[www.groupemedicos.com](http://www.groupemedicos.com)



ZI La Plaine  
01580 IZERNORE  
FRANCE  
Tel. : +33 (0)4 74 76 99 27  
[contact@groupemedicos.com](mailto:contact@groupemedicos.com)



Via delle Industrie, 15/11  
20020 ARESE - MILAN  
ITALIE  
Tel. : +39 02 938 1736  
[contact@groupemedicos.com](mailto:contact@groupemedicos.com)



1, rue Champ Frevan  
39360 CHASSAL  
FRANCE  
Tel. : +33 (0)3 84 42 43 98  
[contact@groupemedicos.com](mailto:contact@groupemedicos.com)